



MESA DAY CONTEST RULES 2021-2022 (DRAFT)

Moon Base

| | |
|-----------------------------|--|
| LEVEL: | Middle School (MS) & High School (HS) |
| DIVISION(S): | Grade 6 and Grades 7/8 (MS); Grades 9/10 and 11/12 (HS) |
| COMPOSITION OF TEAM: | 2-3 Students per team |
| NUMBER OF TEAMS: | Preliminary – Determined by your local MESA center Regional – # of teams per division at the discretion of each region (Northern, Central, LA Metro, and Southern) |
| SPONSORS: | California State University, East Bay MESA College Prep Center San Jose State University MESA College Prep Center |

OVERVIEW: In the near future space agencies from many nations are planning to return to the moon. There are plans to establish “permanent” research stations. As is obvious from the many craters on the moon visible from the Earth, meteor strikes are a relatively common occurrence with devastating results. Your task is to design a safe structure to house these new moon-based research activities. Students will design and construct an original structure using only recycled cardboard that can withstand the highest amount of impact, is lightweight, and meets the specific size requirements outlined below. **Participation logistics, limits, and competition facilities may vary by host site. Advisors and students are responsible for verifying this information with their local MESA center.**

An Engineering Lab Book is a required component of this competition. The purpose of the Engineering Lab Book is for students to better understand the process an engineer goes through in the creation of a project. MESA projects are not designed to be completed in a single class period or day, but to be the result of thoughtful research, planning, analysis, and evaluation. Keeping a lab book throughout the design process will help to keep a designer on track, using a logical progression of planning, in order to develop their project efficiently.

MATERIALS: For the structure, the only allowable material is recycled, un-coated, and unpainted cardboard.

- No other materials are allowed

For the Engineering Lab Book, **electronic submission will be required.** Teams should use an electronic portal/application such as Google Docs to keep and maintain a lab book. Access and permission to the lab book must then be given to MESA Day staff and judges OR lab book is submitted electronically (e.g., PDF file, WORD file) for review. **Please check with your local MESA center for the deadline and submission platform to submit your team's lab book for local and for regional events.** See “MESA Day 21_22 Engineering Lab Book Guidelines” at <https://mesa.ucop.edu/>.

The Host Center will provide the following during the competitions::

- Safety Goggles
- Scale for weighing the structures
- The Impact Testing Device for testing
- A 12 ounce standard soda can (with height of 12.1 cm) for the Astronaut
- Glow in the Dark paint

GENERAL RULES:

- 1) The students' full name, grade level, school name, and MESA center must be clearly labeled on the structure. A 10% penalty in the score will be assessed for failing to properly label.
- 2) Only recycled, un-coated, and unpainted cardboard (up to a maximum thickness of 5 mm) or paper-based materials can be used to create the structure (polymers, wood, metal, ceramics, etc. are not allowed). After the project has been tested, there will be a forensic inspection to ensure that there are no additional materials used on the internal structure and no cardboard is thicker than 5mm.
- 3) All joints or connections must be created with allowed materials; no glue, tape, or other external adhesive of any type can be used in any way or form. Carved, mortise, and tenon, or other systems using exclusively cardboard or paper products are allowed.
- 4) The structure MUST fit within the space defined by the following specifications (See Figure 1):
 - a. Maximum length = 55 cm
 - b. Maximum width = 55 cm
 - c. Maximum height = 25 cm
 - d. Minimum interior clearance = must fit a 20 cm radius half sphere in the center.
 - e. Maximum Structure Weight = 100 grams
- 5) Structure must have two openings (doorway) with a minimum dimension of 10 cm that allow the “astronaut” to be seen by the audience and to allow the inspection of the structure.
- 6) No material (e.g., paint, varnish, hairspray, etc.) may be applied to the structure. Ink or pencil is allowed to identify students' full name, grade level, school, and MESA center.
- 7) Project must be the original work of the student. Judges may ask questions to confirm provenance.
- 8) Please remember that the purpose of this contest is to use creativity to build the best structure within the framework of the rules. The purpose is not to break the rules and see if you can get away with it.
- 9) Digital media (e.g., photos, video recordings, etc.) will not be accepted for arbitration purposes.
- 10) The lab book is meant to clearly demonstrate and illustrate evidence of the application of the Engineering Design Process in the MESA project.

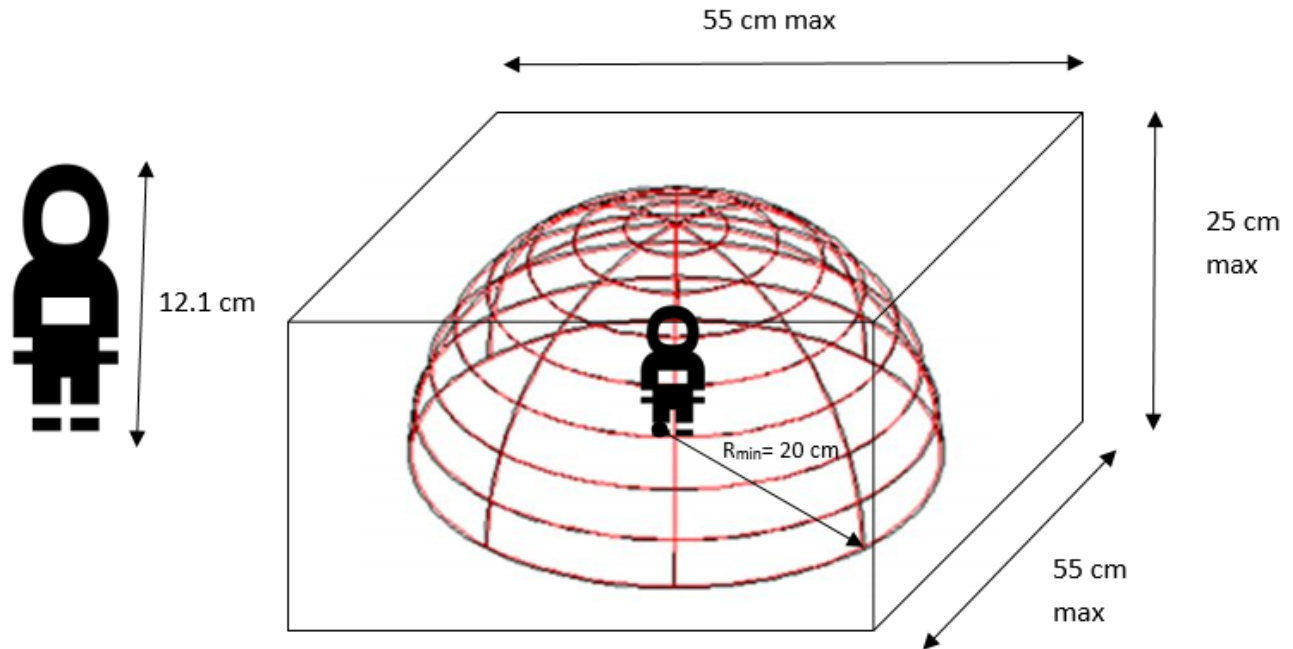

Fig 1. Clearances and dimensional specifications for space to fit the structure.

JUDGING:

- 1) Prior to load testing, the structure receives a specification check to determine whether it conforms to the weight, dimension, and construction rules.
- 2) The competing structure is weighed and its mass " m_s " recorded in grams.
- 3) The structure will be centered under the impact testing device on a flat and sound surface (see Attachment A for details). A "crash test dummy astronaut" (i.e., a 12 ounce standard soda can) with a height of 12.1 cm will be centered in the interior space.
- 4) A load with a mass " m_l " (in grams) will impact the structure, starting at an elevation of 50 cm, measured from the flat surface where both the structure and testing device are standing. After the impact, the judges will verify if the astronaut body touched the structure. The hitch ball (see Attachment B: Testing Device Construction Materials), used as the load, will need to be weighed (" m_l ") prior to testing.
 - a. The Host Center will provide a 12.1 cm tall "astronaut" made of a 12 ounce standard soda can. A drop of glow-in-the-dark paint will be placed on the top of the "astronaut's head" to see if the structure hit the astronaut.
- 5) If the structure did not touch the astronaut, the height of the impact will be increased by increments of 25 cm up to 200 cm (i.e., 75 cm, 100 cm, 125 cm, 150 cm, 175 cm and 200 cm). The impact height " H " (in cm) is the highest measured impact height that still protects the astronaut. A structure that does not protect the astronaut at its initial impact height of 50 cm will be disqualified.
- 6) Disqualified structures are not eligible for awards in any category. However, they may be tested in private, time permitting.

7) The structures will be judged by their Impact-to-Mass Ratio, “I/M” calculated as:

$$I/M = m_i * g * (H * 10^{-2}) / m_s$$

Where: m_i is the mass of the hitch ball in grams; g is the gravity, 9.81 m/s^2 ; H is highest impact elevation in centimeters; and m_s is the mass of the competing structure in grams.

8) A deduction of 20% of the team score will be assessed for an incomplete lab book and a deduction of 50% of the final score will be assessed for a missing lab book.

AWARDS:

- Awards will be given per division: Grade 6 and Grades 7/8 (MS) and Grades 9/10 and Grades 11/12 (HS).
- Medals will be awarded for 1st, 2nd, and 3rd place based on the best Impact-to-Mass Ratio.
- Ribbons will be awarded for Creativity and Engineering Design.
- Only teams that place in the Impact-to-Mass Ratio category will advance to Regional MESA Day; please check with your local MESA center to determine the number of teams that advance to Regional MESA Day.

ATTACHMENTS/APPENDIX:

- A: Impact Testing Device
- B: Testing Device Construction Materials

A: IMPACT TESTING DEVICE

This device has been designed in such a way that it can be safely built by the MESA students with teacher supervision. All materials are standard and can be found at the local hardware store

1) Materials (Note that the tester could be built using PVC pipe, but ABS is more impact resistant, easier to cut and glue, and is a more sustainable product):

| ID | Qty | Item |
|-----|-----|---|
| (a) | 2 | 1 ½ inch ABS pipes (10 ft standard length) |
| (b) | 2 | 1 ½ inch ABS 90 degree Tee (NIBCO 1-1/2 in. ABS DWV All Hub Sanitary Tee) |
| (c) | 2 | 1 ½ inch ABS 90 degree short elbow (NIBCO 1-1/2 in. ABS DWV 90° Hub x Hub Vent Elbow) |
| (d) | 1 | 1 ½ inch ABS double Tee (NIBCO 1-1/2 in. ABS DWV All Hub Double Sanitary Tee) |
| (e) | 4 | 1 ½ inch ABS caps (NIBCO 1-1/2 in. ABS DWV Hub Cap) |
| (f) | 1 | ABS glue |
| (g) | 1 | Impact Weight |
| (h) | 1 | Pin or screwdriver |
| (i) | 1 | Rope |

2) Tools: hand saw, drill, sandpaper (or file), small level, step stool

3) Construction process:

- I. Cut eight 25 cm long pieces of 1 ½ inch ABS pipe. Finish watch cut with the sandpaper or file.
- II. Build the apparatus feet (2 units) first by gluing two collinear pieces of ABS pipe (Item a) to the Tee. (Item b)
- III. Build the horizontal beam of the apparatus by gluing two pieces of pipe (Item a) to the double Tee (Item d)
- IV. Create the apparatus two columns by gluing one side of the 90 short elbows (Item c) to a piece of ABS pipe (Item a).
- V. Create the apparatus frame by gluing the horizontal beam created in step (III) to the feet created in step (IV). Place this assembly on a flat surface and make sure all pipes are on the same horizontal plane.
- VI. Install the apparatus feet from step (II) to the frame from step (V). Apply glue to the column in the frame and slowly slide each column into the tee at each apparatus foot. Always keep a level on top of the frame to ensure the beam on the frame is horizontal. (see Figure 2).
- VII. Install the caps (Item e) at the ends of each apparatus foot.



Fig 2. Installation of the apparatus feet.

- VIII. Cut the 1 ½ inch pipe (Item a) at 7 feet and mount it on top of the double tee (Item d) at the center of the apparatus. Measure and mark this vertical pipe at an elevation of 50 cm measured from the horizontal surface where the apparatus is standing. Continue measuring and marking the pipe at 25 cm increments until reaching a final mark at an elevation equal to 200 cm.

B: TESTING DEVICE CONSTRUCTION MATERIALS

| Product | Quantity | Unit Price | Link for Purchase |
|---|----------|------------|---|
| 4 oz. Medium Black ABS Cement | 1 | 4.97 | https://www.homedepot.com/p/Oatey-4-oz-Medium-Black-ABS-Cement-309993/100136815 |
| 2 in ABS pipe (10 ft standard length) | 2 | 12.98 | https://www.homedepot.com/p/VPC-2-in-x-10-ft-ABS-Cell-Core-Pipe-29-210HD/309282467 |
| 2 in. ABS DWV All Hub Sanitary Tee | 2 | 3.74 | https://www.homedepot.com/p/NIBCO-2-in-ABS-DWV-All-Hub-Sanitary-Tee-C5811HD2/100347862 |
| 2 in. ABS DWV All Hub Double Sanitary Tee | 1 | 10.46 | https://www.homedepot.com/p/NIBCO-2-in-ABS-DWV-All-Hub-Double-Sanitary-Tee-C5835HD2/100347018 |
| 2 in. ABS DWV 90-Degree Hub x Hub Vent Elbow | 2 | 3.74 | https://www.homedepot.com/p/NIBCO-2-in-ABS-DWV-90-Degree-Hub-x-Hub-Vent-Elbow-C5807VHD2/100344401 |
| 2 in. ABS DWV Cap | 4 | 5.96 | https://www.homedepot.com/p/NIBCO-2-in-ABS-DWV-Cap-C5817HD2/204697207 |
| 5/32 in. x 75 ft. Camouflage Diamond Braid Polypropylene Rope with Winder | 1 | 4.96 | https://www.homedepot.com/p/Everbilt-5-32-in-x-75-ft-Camouflage-Diamond-Braid-Polypropylene-Rope-with-Winder-72575/206094286 |
| 5,000 lb. 2 in. Ball Diameter, 1 in. Shank Diameter, 3 in. Shank Length Chrome Class III Trailer Hitch Ball | 1 | 8.98 | https://www.homedepot.com/p/TowSmart-5-000-lb-2-in-Ball-Diameter-1-in-Shank-Diameter-3-in-Shank-Length-Chrome-Class-III-Trailer-Hitch-Ball-765/206798859 |
| 10 in. Hack Saw with Plastic Handle | 1 | 5.97 | https://www.homedepot.com/p/Anvil-10-in-Hack-Saw-with-Plastic-Handle-12750/303858480 |
| Pro Grade Precision 3-2/3 in. x 9 in. Faster Sanding Sheets 60 Grit Coarse (6-Pack) | 1 | 4.97 | https://www.homedepot.com/p/3M-Pro-Grade-Precision-3-2-3-in-x-9-in-Faster-Sanding-Sheets-60-Grit-Coarse-6-Pack-127060PGP-6/313353720 |
| 9 in. Torpedo Level | 1 | 4.97 | https://www.homedepot.com/p/Empire-9-in-Torpedo-Level-587-24/100653523 |

Note: It will be necessary to drill holes and have a pin to release the hitch ball.