



MESA DAY CONTEST RULES 2017-2018

Wright Turn Glider Competition

| | |
|----------------------------|--|
| LEVEL: | Grades 9 – 12 |
| TYPE OF CONTEST | Individual/Team |
| COMPOSITION OF TEAM | 2-3 students per team 9 th -10 th ; 2-3 students per team 11 th -12 th |
| NUMBER OF TEAMS | Preliminary – As determined by local MESA Center Regional – 3 for 9 th – 10 th , 3 for 11 th – 12 th |
| SPONSOR: | Vonna Hammerschmitt, Director, Chapman University MESA |
| OVERVIEW: | <p>Students will design and construct a glider that, when launched by the officially supplied launcher, flies through the air, makes a right-hand turn, and lands on an “X” 12.2 meters (40 feet) from the launch area. Project must be the original work of the student. Judges may ask questions for verification. Participation logistics and limits and competition facilities may vary by host site. Advisors and students are responsible for verifying this information with their Center Director.</p> |

An engineering notebook is a required component of this competition. The purpose of the Engineering Notebook is for students to more closely follow the practices of an engineer in the completion of their MESA Day project. The Engineering Notebook will encourage students to take a purposeful and sustained approach to building their devices. MESA projects are not designed to be completed in a single class period or day, but to be the result of thoughtful research, planning, analysis and evaluation. The notebook should provide a written record of the thought and insight that a student put into their project, from initial ideas to the final completed project. **Projects without engineering notebooks will receive a 20% deduction from their total score.**

Proper labeling is required for all gliders. The students' full name, school name, grade and MESA Center must be clearly labeled on the device. A 10% penalty in the score will be assessed for failing to properly label.

MATERIALS:

LEGAL: Any materials may be used to build the glider; Materials are **not** limited to wood. Students should consider the strength of the material needed to withstand the force of the launcher.

ILLEGAL:

- No power (thrust, lift or stored energy that assists dynamic flight) may be supplied by any means other than that provided by the official launcher
- No remote control devices of any kind

For the Engineering Notebook. Any standard notebook, including but not limited to spiral and subject notebooks and compositions books may be used. Notebook page size must be equivalent or greater than that of a composition book page (approx. 9.75" in length X 7.5" in width). Pocket size notebook, post-it notes, flashcards, etc. cannot be used. Computer generated notebook and/or pages are allowed.

Engineering Notebook and glider must be clearly labeled with student name, school, grade and MESA Center. **Notebooks and/or gliders not properly labeled will be assessed a 20 % deduction from the total score.**

The Host Center will provide the official launcher describe in these rules appropriate table for launcher and safety goggles.

Suggested judging materials: Measuring tape, stopwatch to determine hangtime, tape or chalk to designate target "X".

RULES:

1. The glider is a self-contained flying vehicle that remains intact during flight. Parts that break-off during landing are permissible but are not encouraged. If parts of the glider break-away during flight, the flight will be disqualified.
2. The glider must contain a feature that adapts to the launch hook to allow for a smooth launch.

3. Any glider that alters or damages the launch “hook” will be disqualified.
4. The glider must have features to avoid getting caught in the “slot” in the launch ramp. Wheels and skids must be positioned to avoid the “slot”.
5. The glider can be made from any materials. There are no restrictions on size or weight. The glider must be capable of being launched on the launch ramp by the hook and must have an identifiable fuselage, wing and tail. Gliders without the required components will be disqualified.
6. Absolutely no remote-control devices of any kind may be used. Any devices that operate on the glider must be self-contained and may not provide any thrust to the glider.
7. Absolutely no power (thrust, lift, or stored energy that assists dynamic flight) may be supplied by any means other than that provided by the official launcher.
8. The glider must be capable of self-sustained flight in air with no links of any kind to the ground that provide lift, propulsion or course guidance during the flight.
9. The engineering notebook must contain the following sections with each section tabbed/labeled:
 - a. Proper Labeling
 - i. Proper labeling is required of each notebook. Students must have group member names, grades, school and MESA center on the inside cover of their MESA Engineering Notebooks.
 - b. Project Introduction
 - i. A one page introduction for the project. Students can write about why they chose the project that they are worked on and what challenges they expect to run into with this project. They may also briefly describe the project criteria and constraints. This introduction should be honest and genuine.
 - c. Daily Entries
 - i. At least ten daily entries will be required. Each entry must have the date of entry and be at least half a page long. They should answer the following questions:
 - What did you work on/discuss today?
 - What was the result of your work?
 - What do you need to do during your next meeting?
 - d. Project Sketches
 - i. Notebooks must contain at least two distinct project sketches that should be placed towards the back or end of the completed notebook pages. The sketches should indicate a progression in the thinking and design of the device, and be detailed. Sketches must be larger than half a page, and can either be drawn on the notebook page directly or attached.
 - e. Applied Mathematics

- i. Notebooks must contain evidence of applied mathematics principles as it pertains to the project. This section **MUST** include the calculations for all of the following:
 1. Calculate the speed of your glider by using $d = rt$.
 2. Calculate the surface area of your glider by measuring the length and width of each section of the glider (wings, tail, fuselage) using the proper formula.
 3. Calculate the efficiency of your glider using distance and mass.
 4. Calculate the center of mass of your glider.

OFFICIAL LAUNCH DEVICE:

1. The official launcher consists of a tension spring, a launch platform and a launch “hook”.
2. The tension spring is an 11” spring with a 0.17 pound per inch spring rate. It is available from **McMaster-Carr and is Part Number 9640K243**. It will be stretched 30.0 inches from its final position. The estimated tension load in the spring at the start of launch is 5.87 pounds. After launch the final length of the spring is 1.25”. In the final position, the spring has a load of 0.77 pounds. In the completely relaxed state, the spring has a preload of 0.73 pounds. The spring has an outer diameter of 1.00” and a wire diameter of 0.062 inches. The mass of the spring is 170 grams.
3. The launch platform has an overall surface size of 30.5 cm (12 inches) in width and 147 cm (58 inches) in length. The surface is hard and smooth and made from ¼” thick composite board or comparable material. A slot runs down the middle of the platform that is 5/35 mm (0.2 inches) wide and is 8 cm (31.5 inches) long. The end of the slot is located 30.5 cm (12 inches) from the end of the launch ramp. The launch ramp is angled at 5 degrees above horizontal. The height of the ramp at the point where the hook stops moving is 100 cm (39.4 inches) above the target.
4. The launch hook is made from steel wire with a 3.4 mm (0.135 inch) diameter. It is available from **McMaster-Carr and is part Number 9594T14**.
5. The hook is screwed into a glide block mounted underneath the launch ramp. The mass of the hook and glide block is 35 ± 2 grams.

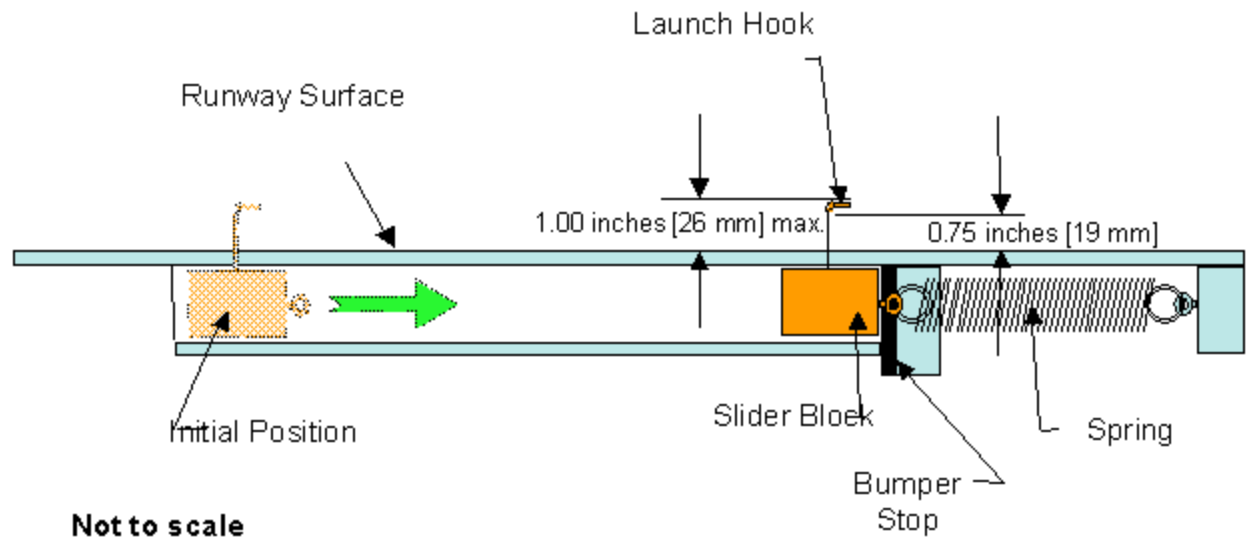

Figure 1: Launch Device – Side View

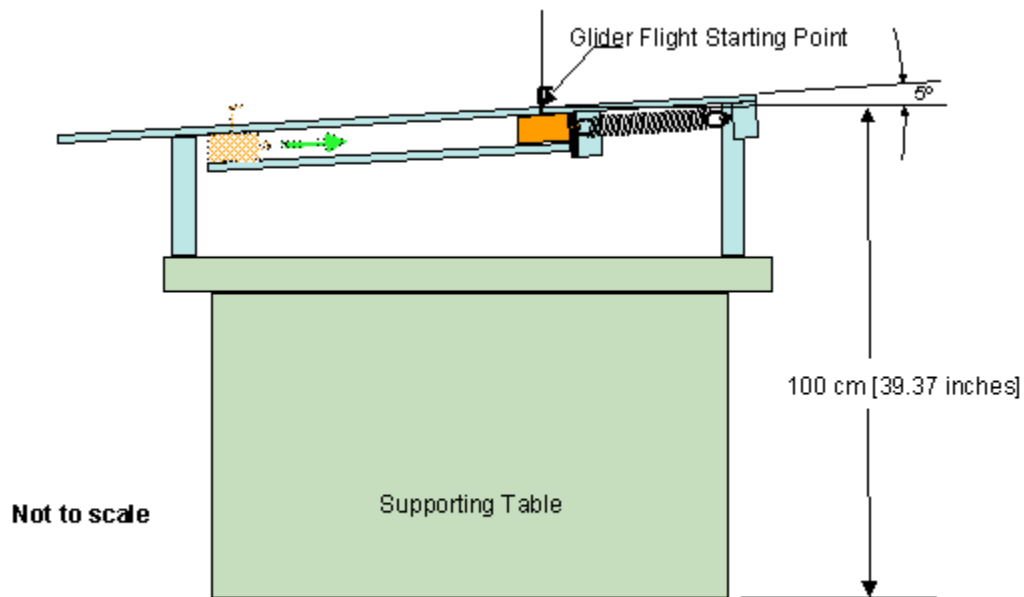
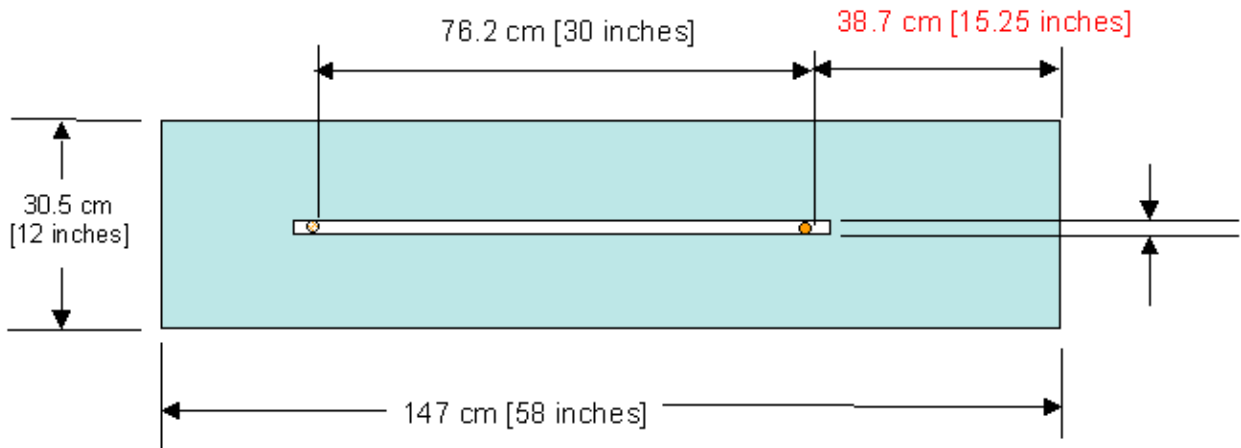

Figure 2: Launch Device Set-up – Side View



Not to scale

Figure 3: Launch Device – Top View

TARGET AND LAUNCH:

1. The target is located at a distance of 8.6 meters (29feet 3 inches) in front of the position where the hook stops on the launch ramp and 8.6 meters (28 feet 3 inches) to the right of the position where the hooks stops on the launch ramp for a total distance of 12.2 meters (40 feet) from the position where the hook stops on the launch ramp. The target is 100 cm (39.4 inches) below the position where the hook stops on the launch ramp. The target is a "+" sign wherein each leg is 3 cm side and 20 cm long comprised of black plastic tape.
2. Each team shall have two opportunities to land their glider the closest to the target. The launches may not be consecutive depending on schedule limitations. The team will be given a five-minute window to set-up their glider. A 30-second countdown will be given prior to the official started pulling the release pin to initiate flight.
3. Timers will time the duration of the flight to the nearest 100th of a second. The flight ends when the first part of the glider touches the ground. Official observers will carefully note where the glider first touches down (wheel, skid, or other feature) using a chalk mark as an indicator.
4. The decision of the observers on the location of the chalk mark is final and is not subject to debate. The team will then remove their glider from the contest area.

- After completion of both flight attempts, the contestant will be asked to place their entry in an area designated by contest officials for further judging and inspection for rule compliance.
- The distance between the target center and the glider's first touch-point will be measured to the nearest 2 cm (0.75 inches). In case of a tie, the longer flight duration (hang-time) will be used as a tie-breaker. If the entries are still tied, equal medals will be awarded.

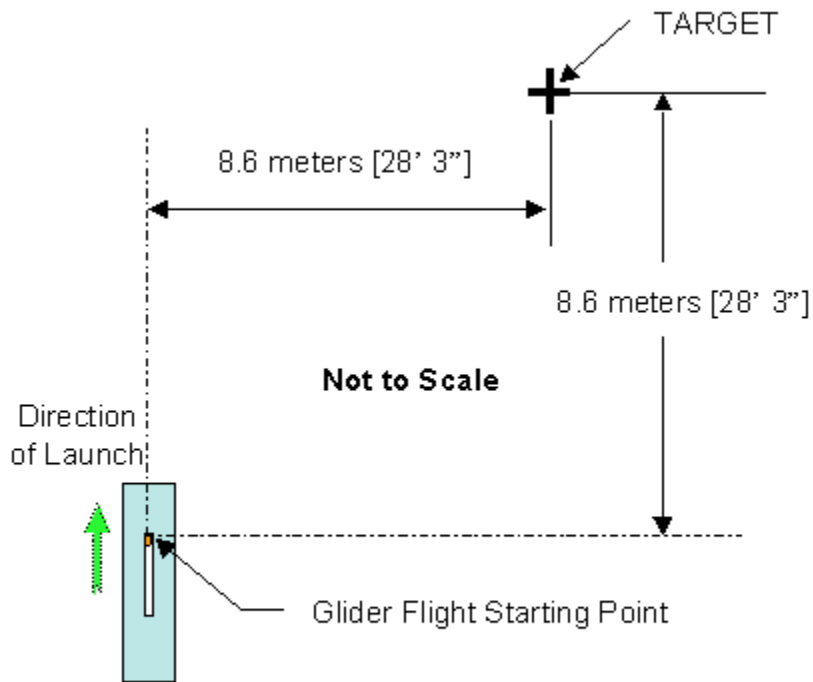

Figure 4: Contest Area – Top View

AWARDS:

- 1st, 2nd and 3rd place medals will be awarded to 9th/10th grade and to 11th/12th grade.

ATTACHMENTS/APPENDIX:

ATTACHMENTS/APPENDIX:

#1 – Specification Check list

#2 – Engineering Notebook Grading Ruberic

**† WRIGHT TURN GLIDER
SPECIFICATION CHECK and SCORING SHEET**

- Glider has no remote controls
- Glider has no power thrusts – the only power is provided by the launcher
- Capable of self-sustained flight with no links to the ground for lift, propulsion or guidance
- Device adapts to launch hook on official launcher
- Glider is original work of the students

SCORING:

Launch #1 Distance from the “X” target = _____

Launch #2 Distance from the “X” target = _____

Score for the best launch = _____ - 20% possible deduction from Notebook Score =

FINAL SCORE _____

MESA DAY 2017-2018

Engineering Notebook Requirement Rubric

Please use this rubric to assess notebook entries. An incomplete or missing notebook will lead to a 20% deduction from the total team score.

| Criteria | | YES | NO |
|--------------|---|-----|----|
| 1 | Is the notebook properly labeled? <i>(Names, Grades, School, MESA Center)</i> | | |
| 2 | Does the notebook contain a one page introduction to the project? <i>(On the first page of the notebook)</i> | | |
| 3 | Are there at least 10 dated entries in the notebook? | | |
| 4 | Is each entry at least half a page long? | | |
| 5 | Are there at least two distinct project sketches included? | | |
| 6 | Is there evidence of the following applied mathematics principles? - Calculate the speed of the glider by using $d = rt$. - Calculate the surface area of the glider. - Calculate the center of mass of the glider. | | |
| TOTAL | | | |

Does the notebook meet the requirement? (circle one)

YES **NO**

Notebooks must meet ALL criteria to fulfill this requirement