



**JPL INVENTION CHALLENGE
WRIGHT TURN GLIDER CONTEST
2016-2017**

LEVEL:	Grades 9 – 12
TYPE OF CONTEST	Individual/Team
COMPOSITION OF TEAM	2 – 6 students per team
NUMBER OF TEAMS	3 Teams Per Center
SPONSOR:	Vonna Hammerschmitt, Director, Chapman University MESA

OVERVIEW: Students will design and construct a glider that, when launched from the officially supplied launcher, flies through the air, makes a right-hand turn, and lands on an “X” 12.2 meters (40 feet) from the launch area. **Project must be the original work of the students. Judges may ask questions for verification.**

MATERIALS:

LEGAL:

Any materials may be used to build the glider

ILLEGAL:

- No power (thrust, lift or stored energy that assists dynamic flight) may be supplied by any means other than that provided by the official launcher
- No remote control devices of any kind

RULES:

1. The glider is a self-contained flying vehicle that remains intact during flight. Parts that break-off during landing are permissible but are not encouraged. If parts of the glider break-away during flight, the flight will be disqualified.
2. The glider must contain a feature that adapts to the launch hook to allow for a smooth launch.

MESA DAY CONTEST RUELS 2016-2017

Master Set

©University of California Regents

These materials are for the internal use of MESA staff and teachers only and should not be forwarded to used outside of MESA

3. Any glider that alters or damages the launch “hook” will be disqualified.
4. The glider must have features to avoid getting caught in the “slot” in the launch ramp. Wheels and skids must be positioned to avoid the “slot”.
5. The glider can be made from any materials. There are no restrictions on size or weight. The glider must be capable of being launched on the launch ramp by the hook.
6. Absolutely no remote-control devices of any kind may be used. Any devices that operate on the glider must be self-contained and may not provide any thrust to the glider.
7. Absolutely no power (thrust, lift, or stored energy that assists dynamic flight) may be supplied by any means other than that provided by the official launcher.
8. The glider must be capable of self-sustained flight in air with no links of any kind to the ground that provide lift, propulsion or course guidance during the flight.

OFFICIAL LAUNCH DEVICE:

1. The official launcher consists of a tension spring, a launch platform and a launch “hook”.
2. The tension spring is an 11” spring with a 0.17 pound per inch spring rate. It is available from McMaster-Carr and is Part Number 9640K243. It will be stretched 30.0 inches from its final position. The estimated tension load in the spring at the start of launch is 5.87 pounds. After launch the final length of the spring is 1.25”. In the final position, the spring has a load of 0.77 pounds. In the completely relaxed state, the spring has a preload of 0.73 pounds. The spring has an outer diameter of 1.00” and a wire diameter of 0.062 inches. The mass of the spring is 170 grams.
3. The launch platform has an overall surface size of 30.5 cm (12 inches) in width and 147 cm (58 inches) in length. The surface is hard and smooth and made from ¼” thick composite board. A slot runs down the middle of the platform that is 5/35 mm (0.2 inches) wide and is 8 cm (31.5 inches) long. The end of the slot is located 30.5 cm (12 inches) from the end of the launch ramp. The launch ramp is angled at 5 degrees above horizontal. The height of the ramp at the point where the hook stops moving is 100 cm (39.4 inches) above the target.
4. The launch hook is made from steel wire with a 3.4 mm (0.135 inch) diameter. It is available from McMaster-Carr and is part Number 9594T14.
5. The hook is screwed into a glide block mounted underneath the launch ramp. The mass of the hook and glide block is 35 ± 2 grams.

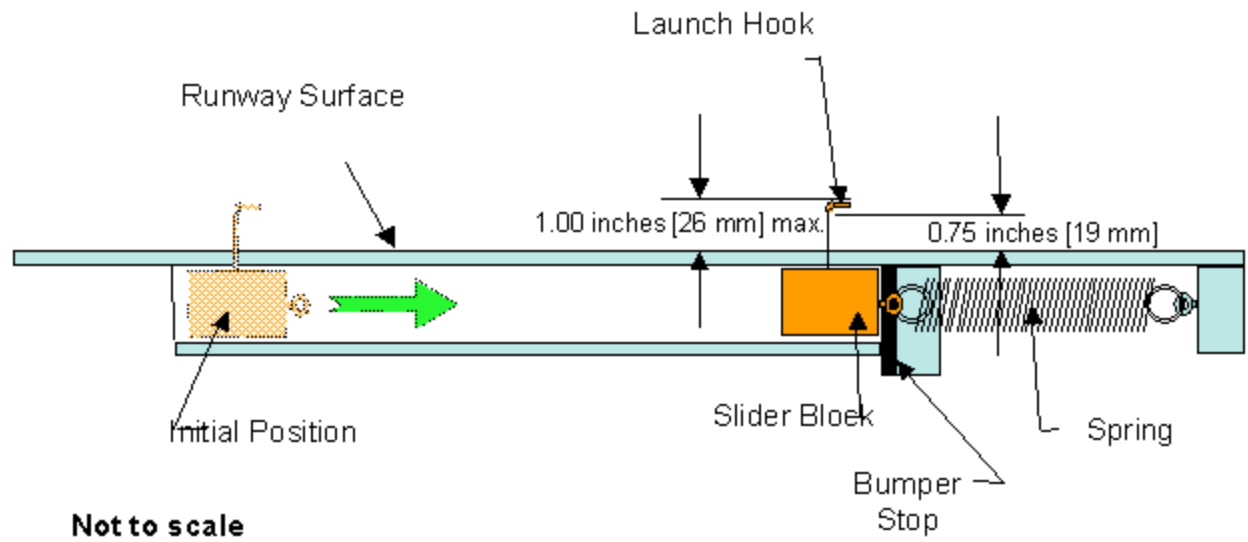

Figure 1: Launch Device – Side View

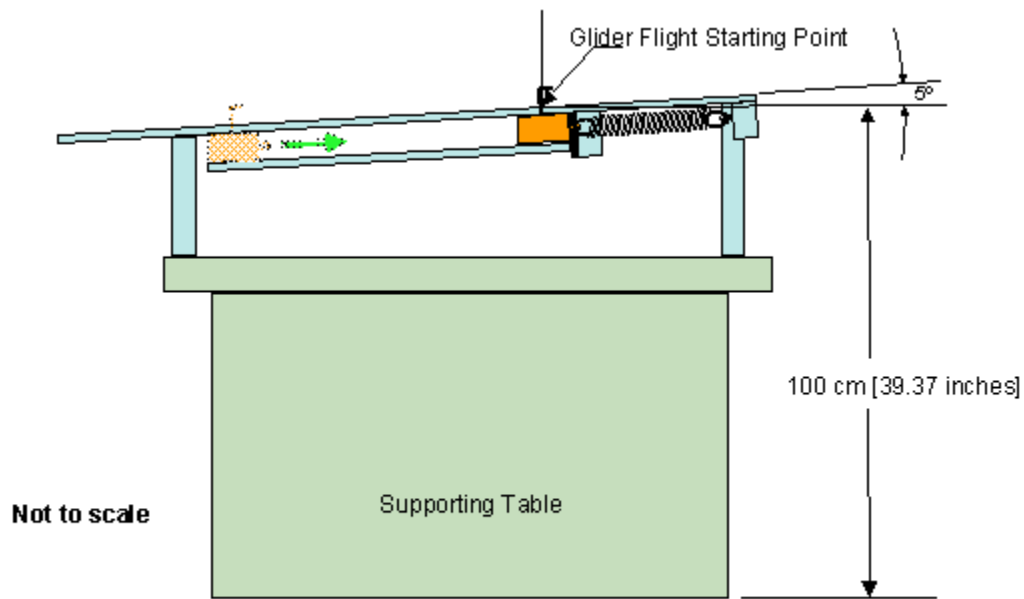
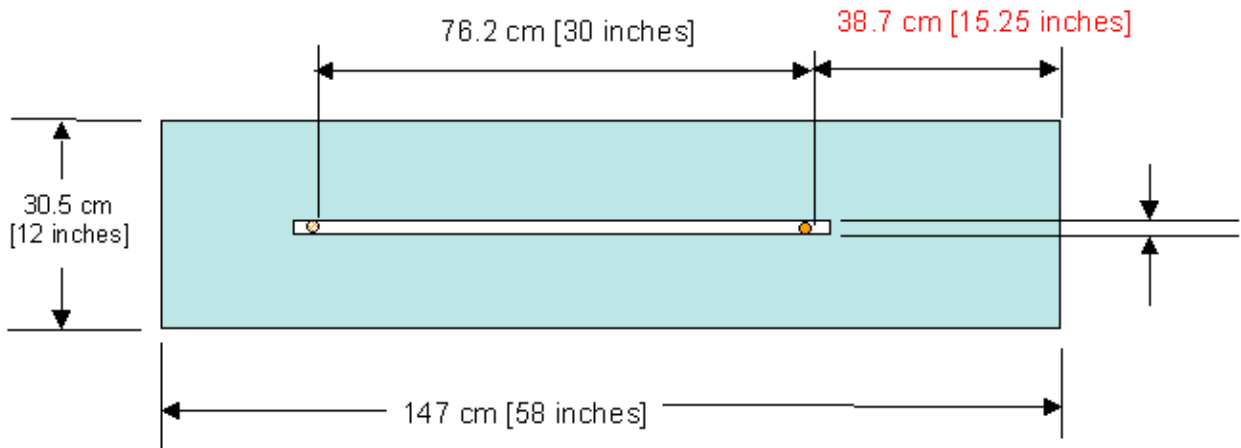

Figure 2: Launch Device Set-up – Side View



Not to scale

Figure 3: Launch Device – Top View

TARGET AND LAUNCH:

1. The target is located at a distance of 8.6 meters (29feet 3 inches) in front of the position where the hook stops on the launch ramp and 8.6 meters (28 feet 3 inches) to the right of the position where the hooks stops on the launch ramp for a total distance of 12.2 meters (40 feet) from the position where the hook stops on the launch ramp. The target is 100 cm (39.4 inches) below the position where the hook stops on the launch ramp. The target is a “+” sign wherein each leg is 3 cm side and 20 cm long comprised of black plastic tape.
2. Each team shall have two opportunities to land their glider the closest to the target. The launches may not be consecutive depending on schedule limitations. The team will be given a five-minute window to set-up their glider. A 30-second countdown will be given prior to the official started pulling the release pin to initiate flight.
3. Timers will time the duration of the flight to the nearest 100th of a second. The flight ends when the first part of the glider touches the ground. Official observers will carefully note where the glider first touches down (wheel, skid, or other feature) using a chalk mark as an indicator.
4. The decision of the observers on the location of the chalk mark is final and is not subject to debate. The team will then remove their glider from the contest area.
5. After completion of both fight attempts, the contestant will be asked to place their entry in an area designated by contest officials for further judging and inspection for rule compliance.

- The distance between the target center and the glider's first touch-point will be measured to the nearest 2 cm (0.75 inches). In case of a tie, the longer flight duration (hang-time) will be used as a tie-breaker. If the entries are still tied, equal medals will be awarded.

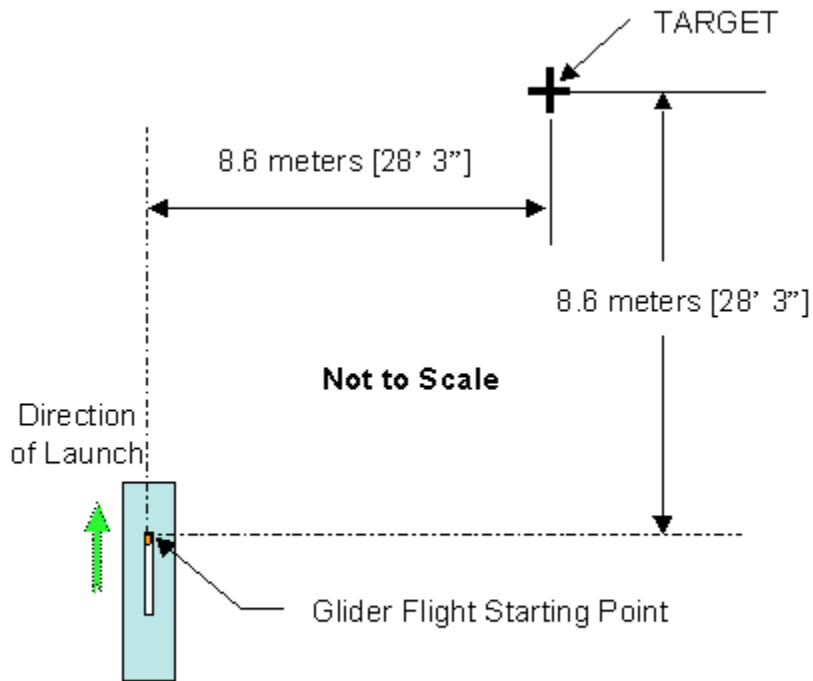

Figure 4: Contest Area – Top View

AWARDS:

- Medals will be awarded for 1st, 2nd and 3rd place.
- Ribbons may be awarded for longest hang time, most creative and most unusual.